

TSTAT5

Microprocessor Based Thermostat Datasheet

TSTAT5 SERIES

This full-featured CPU based thermostat is designed for small cooling and heating air handling systems in residential and commercial facilities. The unit provides features which eclipse standard mechanical thermostats at a price that fits conventional HVAC projects.

The unit comes in several models to suit any mechanical equipment or application.

Highlights:

- Tight control of 0.5°C provides comfortable indoor environment.
- High impact plastic enclosure provides durability in commercial environments.
- Customizable sequence of operation table (FCU with modulating or on/off valve, single or 3-speed fan, pressure independent VAV, stage sequencer...)



Technical Data

TSTAT5A	3 relays x 10amps @220V, 2 analog outputs 10V @ 100ma, 1 analog/digital input
TSTAT5B	3 relays x 10amps @220V, 2 relays @ 1amp 24V or 220V, 1 analog/digital input
TSTAT5C	5 relays x 1amps @24V, 2 analog inputs, 1 digital input
TSTAT5D	same as 5C plus two analog outputs (10V @100ma)
TSTAT5E	5 relays x 1amps @24V, 8 analog inputs, 2 analog outputs (10V @100ma)
Operating temperature.....	-30-70°C (-22~158°F)
Supply voltage.....	12~24VAC/DC ±20%, 50-60Hz
Power consumption.....	100mA at 12VDC
Relay contacts rating.....	max 6A
Ambient humidity.....	10-90 %Rh
Material, enclosure.....	Flame proof plastic
Enclosure rating.....	IP31
Temperature sensor.....	10K thermistor ±0.5°C
Colour.....	White/Off-white
Weight.....	200g

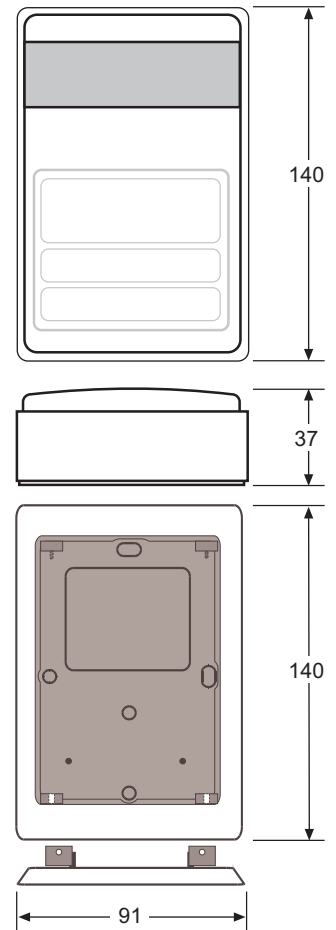

TSTAT5

Microprocessor Based Thermostat Datasheet

Standard Operation

During normal operation the display will show the current room temperature. The first hit on either of the upper pair of keys (Fig.1) will switch the display to showing the current setpoint. Subsequent hits will adjust the room setpoint up or down by 1 degree. The Tstat5 can be set to operate in degrees (Celsius or Fahrenheit) at setup time. After 10 seconds the keypad times out and the display switches back to showing the room temperature (Fig.2).

The lower pair of keys (Fig.3) allows adjustment of the off-on-auto mode and fan speed if applicable. There is flexibility in the modes that can be used. The modes are usually configured at time of installation. The current mode is shown with the first hit on the lower pair of keys and subsequent hits will adjust the mode of operation accordingly.

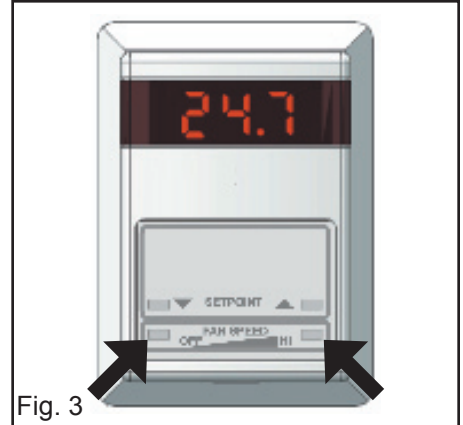
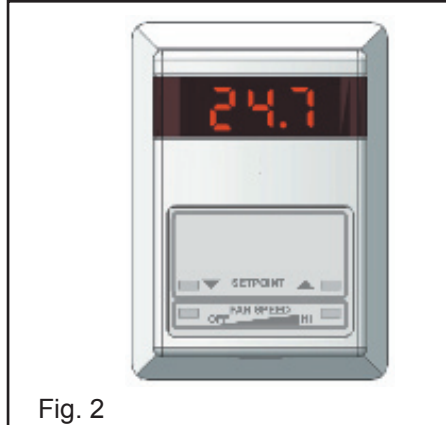
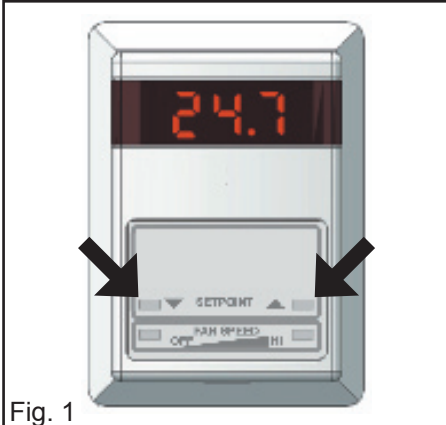

Control Functionality

The controller uses PI (proportional and integral) action, in order to achieve high control accuracy.

The P action takes care of coarse offset corrections. However, when only P control is used, there will be a permanent proportional offset in the room temperature, i.e. the temperature will be kept constant – but at a higher or lower value than the setpoint. This is corrected by the built-in integral action.

The I action senses both the magnitude and the duration of any offset and can, therefore, modulate the control signal, so that any permanent offset is completely eliminated (Figure 4).

The PI parameters (proportional gain and integration time) can be set in advanced menu.

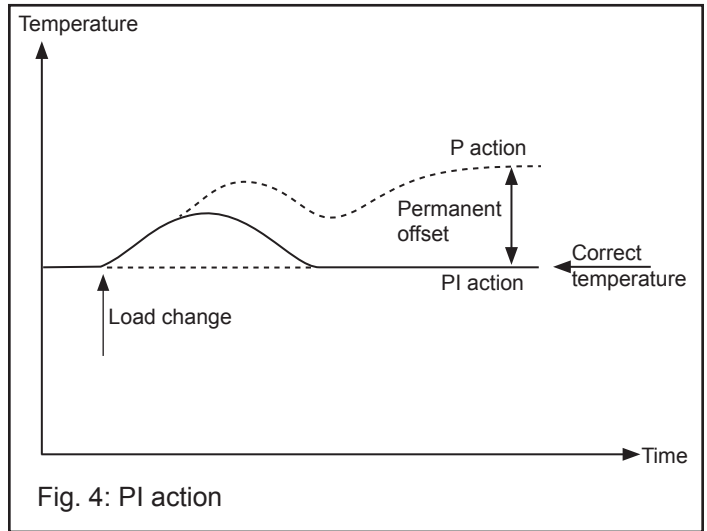

Temperature Sensor

The controller monitors the temperature conditions in the room with its built-in sensor, which is located in the controller so as to not be affected by the temperature of the wall on which it is mounted.

It is possible to connect an external sensor for monitoring the temperature of different locations.

Changes in temperature are monitored continuously at the shortest time interval possible.

TSTAT5

Microprocessor Based Thermostat Datasheet

Installation

Terminal Block Connections (Tstat5A/B)

1.....	24VAC live
2.....	neutral
3,4.....	5A=0-10V, 5B=relay
5.....	External sensor input
6,7,8.....	Network communication
9.....	Common
10,11,12.....	Outputs 220VAC

(Note 3,4 Terminals: The A type has two analog outputs. On the B type, the terminals are on/off type outputs)

Terminal Block Connections (Tstat5C/D)

1.....	24VAC live
2.....	neutral
3.....	Analog input 2
4.....	Analog input 1
5.....	Digital input 1
6,7,8.....	Network communication
9, 10.....	5D=0-10V, 5C=spare
11,12,13,14,15.....	Outputs 24VAC
16.....	Common

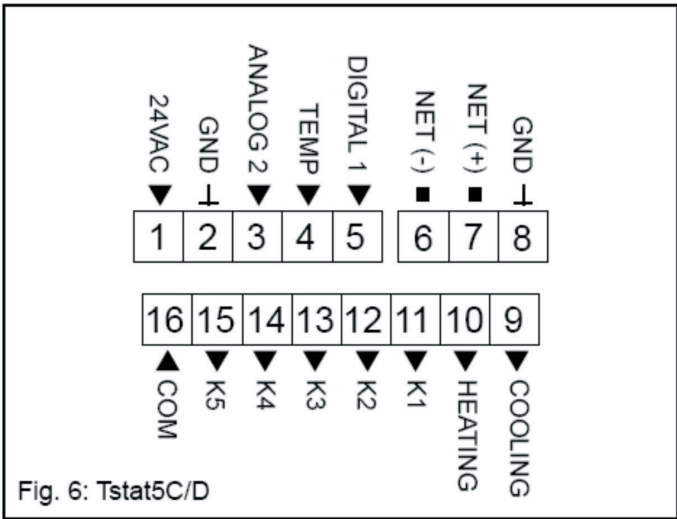
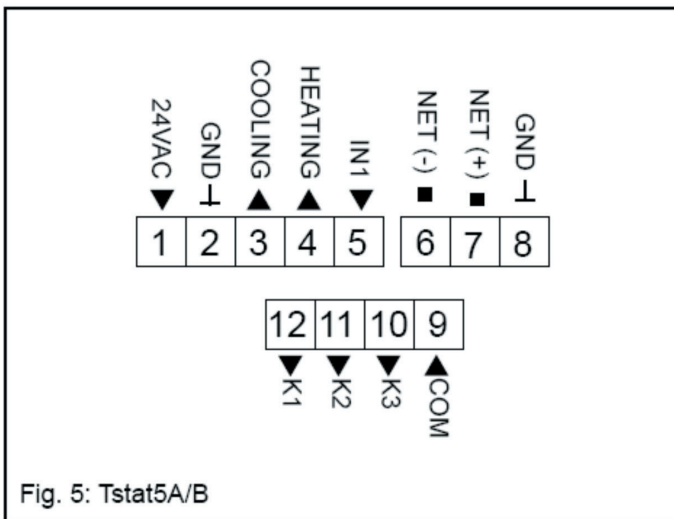

Terminal Block Connections (Tstat5E)

1.....	24VAC live
2.....	neutral
1,2,3,4,5,6,7,8,9.....	Analog input
10,11,12.....	Network communication
13.....	Analogout2
14.....	Analogout1
15,16,17,18,19.....	Outputs 24VAC
20.....	Common

Mounting

External wiring is connected to a terminal block on the circuit board (figures 2 and 3).

The enclosure comprises a base section and a cover. The base section can be mounted directly on a wall or on a wall box. If mounted on a wall box, the cables should enter the enclosure via the hole in the base section.

If mounted directly on a wall, the cables should enter from above.

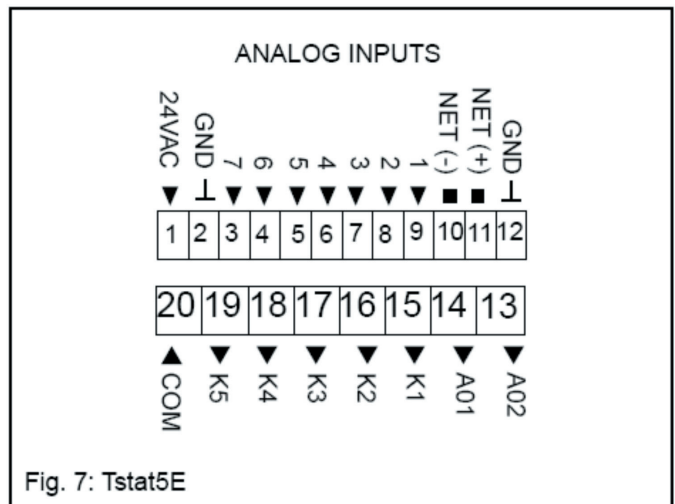

TSTAT5

Microprocessor Based Thermostat Datasheet

Wiring Examples

Tstat5A - 24VAC Modulating Valves, 1-Speed Fan

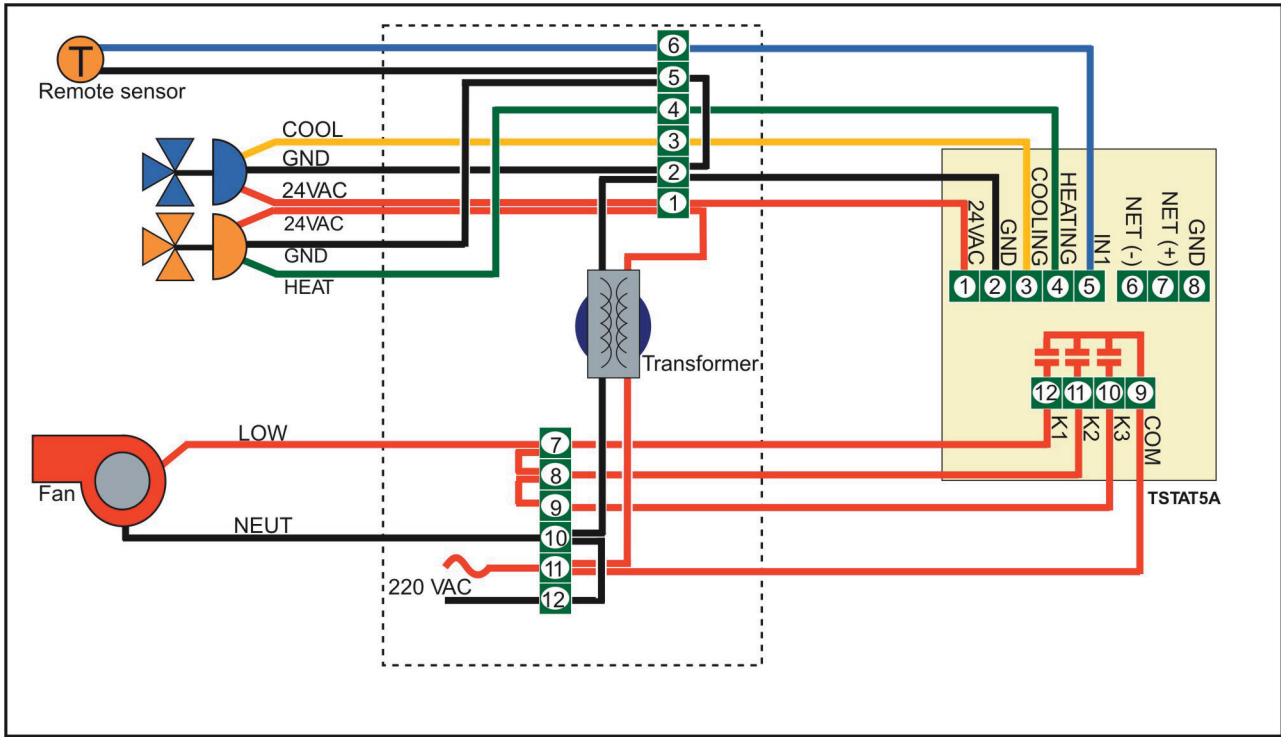

Tstat5B - 220VAC ON/OFF Valves, 3-Speed Fan

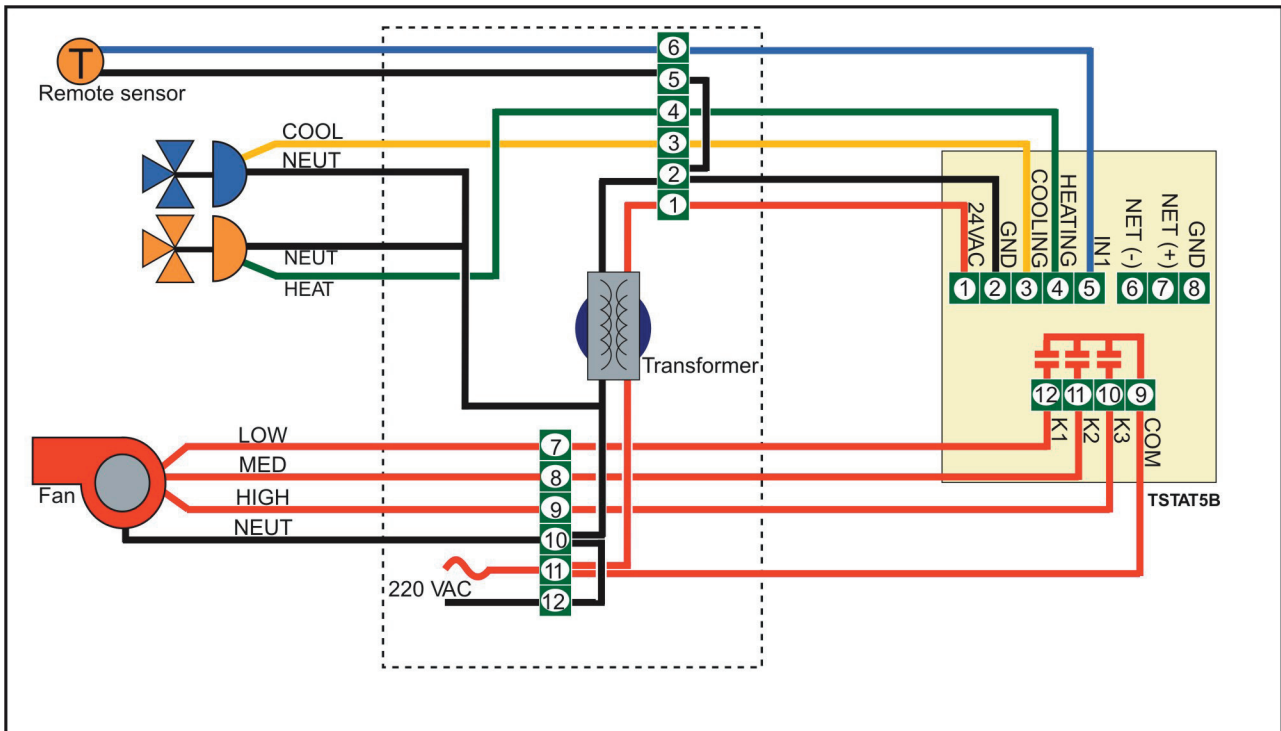

TSTAT5

Microprocessor Based Thermostat Datasheet

Tstat5C - 24VAC ON/OFF Valves, 1-Speed Fan

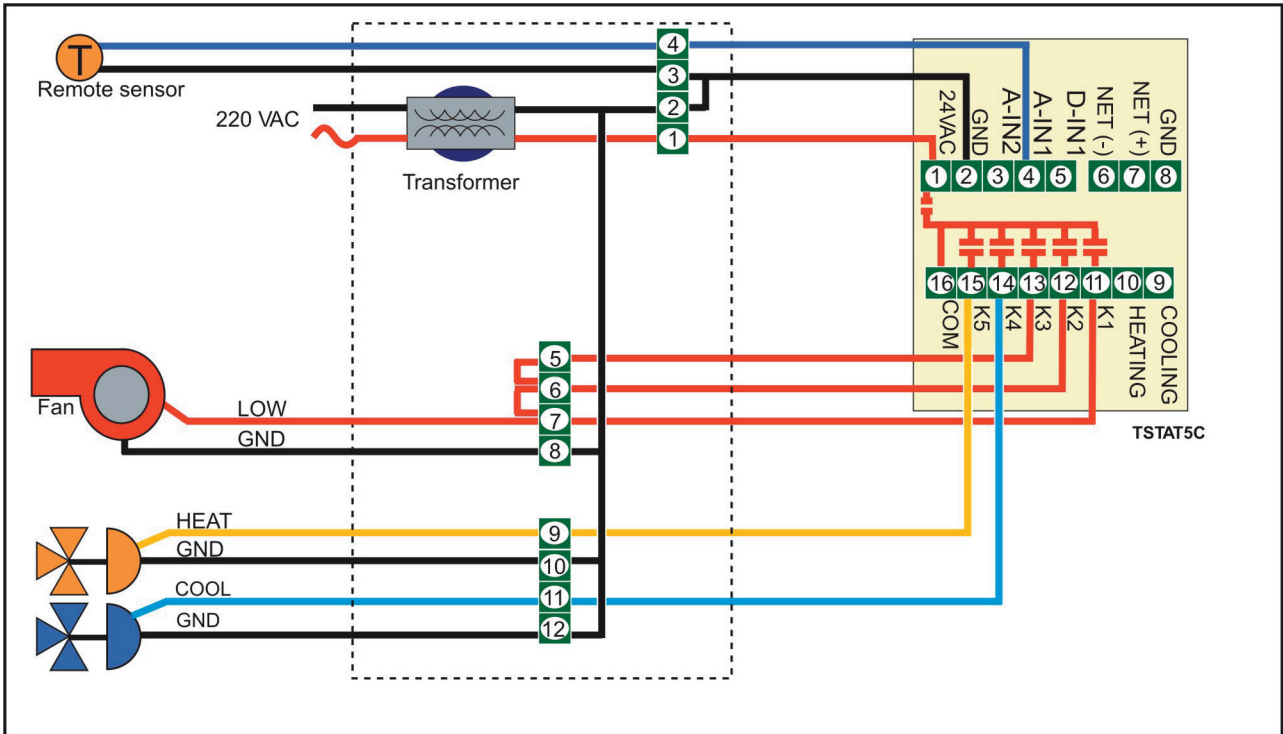

Tstat5D - 24VAC Modulating Valves, 3-Speed Fan

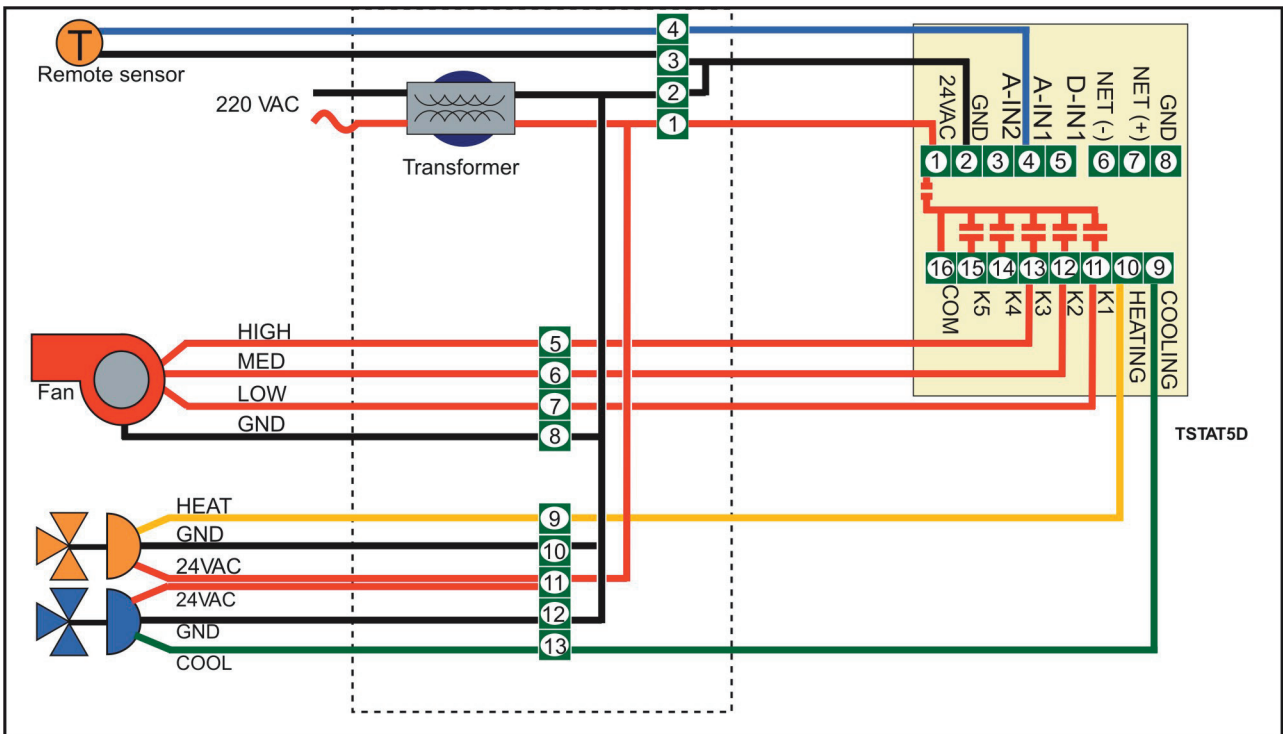

TSTAT5

Microprocessor Based Thermostat Datasheet

Tstat 5E - 24VAC Modulating Valves, 3-Speed Fan, 8AI

